Ground Fault Detection Improvement Study: Mitigation Methods

Greg Ball
DNV-KEMA
(formerly BEW Engineering)

Solar ABCs GFDI Webinar
May 2, 2013

Solar America Board for Codes and Standards



Summary of recommended mitigation methods

Enhanced ground fault monitoring

- Residual current monitoring
- Residual current monitoring with trip
- Electronic sensing in ground circuit
- Isolation monitoring

Sensitized overcurrent protection

- Reduce fuse size in ground fault circuit

Other systemic measures

- Targeted annual O&M practices
- Arc-fault detection

Shown in authors' order of preference for effectiveness and value
Modifications by qualified personnel only and must involve equipment manufacturers!



Method 1: Residual current measurements

With alarm

Installed at inverter entrance on positive and negative feeder circuits

• **Effect:** Major increase in the sensitivity and flexibility of ground fault detection/mitigation

• **Pros:**

- Proven method for detecting blind spot conditions
- Alarm gives operator options for response; reduces impact of false trips

• **Cons:**

- Requires rewire of array conductors through current transducers, and monitor interface
- Does not interrupt the fault current.
- May require installation of a new enclosure to access existing conductors

• **Cost:** Moderate to high

- Possible to run multiple circuits through single CT

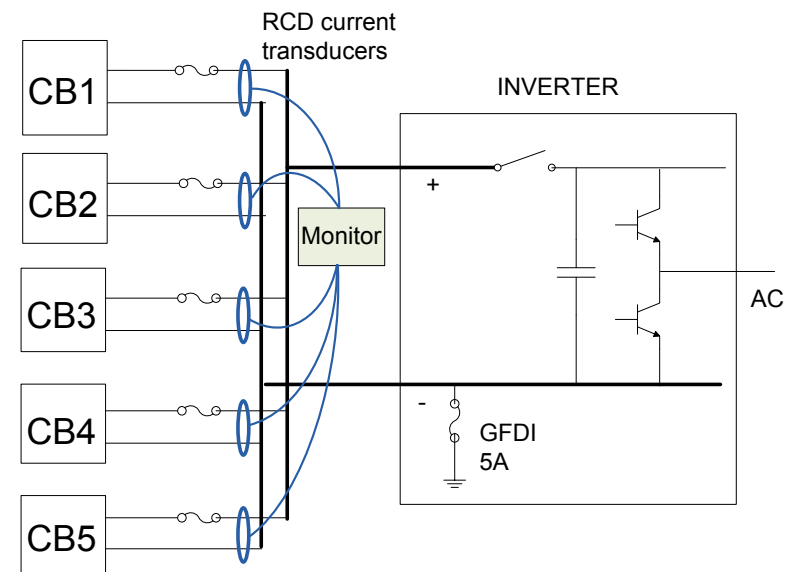
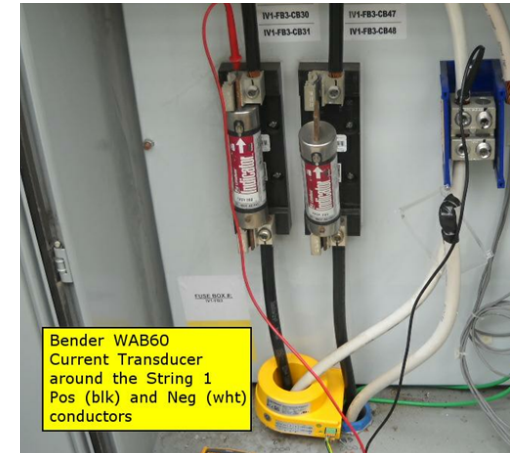

Method 2: Residual current measurements

With auxiliary trip

Similar to method 1, except relay is used to trip inverter off via E-stop, auxiliary trip, or shunt-breaker

• **Effect:** Major increase in the sensitivity of ground fault detection and interruption

• **Pros:**

- Proven method for detecting blind spot conditions.
- Interrupts fault current under blind spot condition
- Data averaging can mitigate false trips caused by lightning or other transients

• **Cons:**

- Requires rewire of array conductors through CTs, possible add'l enclosure.
- Nuisance trips possible
- Inverter trip wiring could have certification/warranty implications

• **Cost:** Moderate to high

- Possible to run multiple circuits through single CT

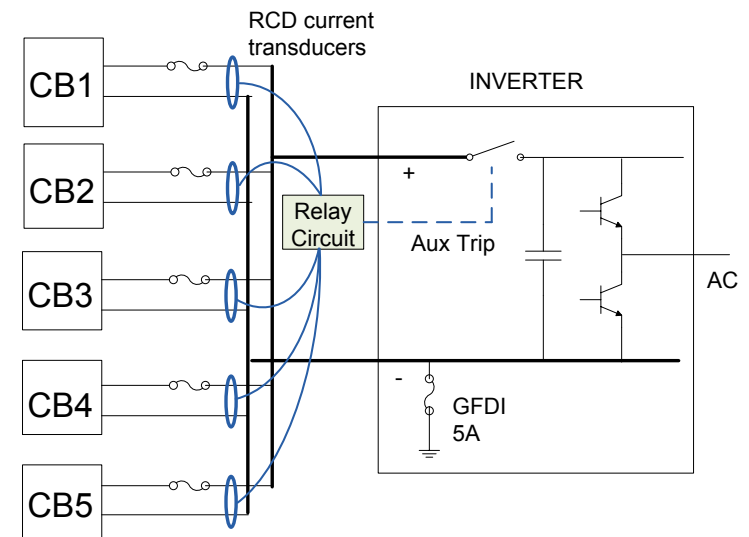

Method 3: Electronic current sense relay in ground circuit

High accuracy sensing is installed in series with ground fault fuse or breaker circuit. Shunt or specialized CT required. Applicable for larger inverters.

- **Effect:** Major increase in the detection sensitivity and mitigation flexibility (~100 mA sensitivity)
- **Pros:**
 - Relays can be programmed to trigger on current and duration levels
 - Can be coordinated with auxiliary trip
- **Cons:**
 - Requires rewire of ground fault fuse circuit
 - False trips possible
 - May impact inverter certification – must have approval from manufacturer.
- **Cost:** Moderate
 - Possible inverter manufacturer retrofit

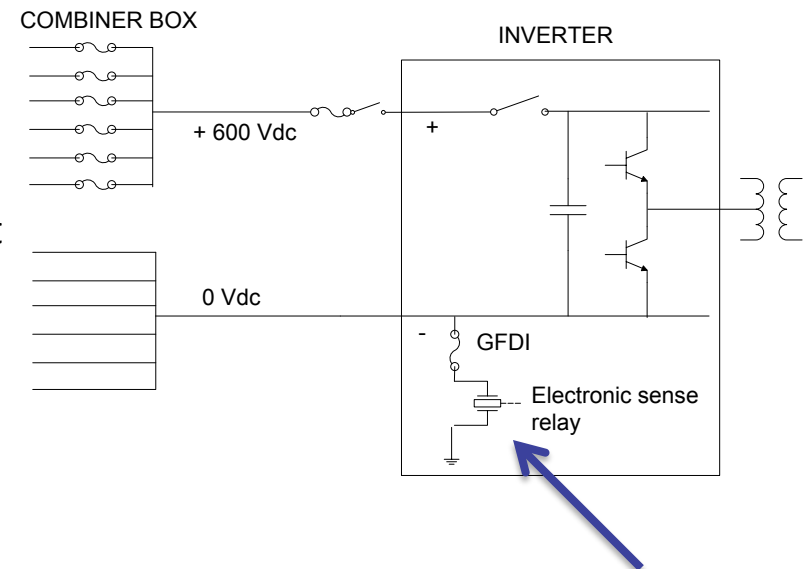

Method 4: Isolation monitoring with periodic check

Install isolation monitor, implement periodic checks

• **Effect:** Capable of detecting low insulation conditions and ground faults on either pole

• **Pros:**

- Proven method for detecting blind spot fault conditions. (Similar to international non-isolated system protection)
- Prevents inverter start up until faults are corrected
- Consistent with evolving UL and IEC standards

• **Cons:**

- More significant changes needed in inverter to implement monitoring, logic control and ground bond contactor

• **Cost:** High (in most cases)

- Involves inverter manufacturer retrofit

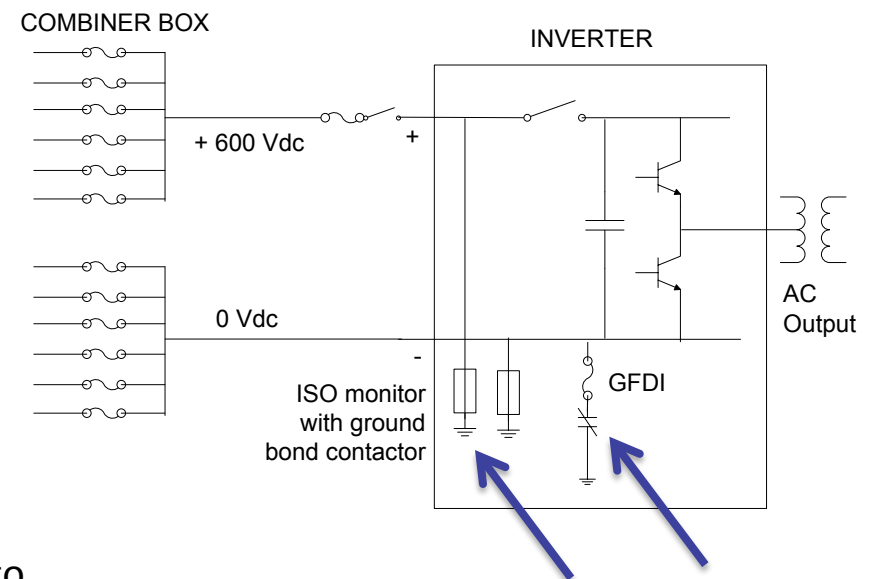

Method 5: Reduce fuse size in ground fault circuit

Replace fuse.

•**Effect:** Minor increase in the sensitivity of ground fault detection.
~10x less sensitive than Methods 1-4.

•**Pros:**

- Easy, inexpensive retrofit

•**Cons:**

- Not as sensitive as electronic ground current monitoring
- May conflict with other inverter functionality
- May impact inverter certification
- May result in nuisance trips

•**Cost:** Low

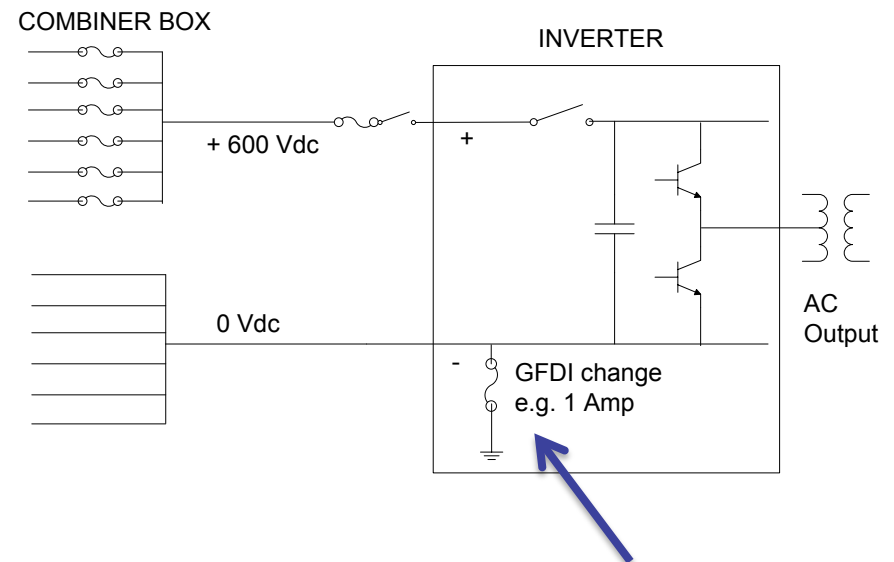

Method 6: Targeted operations and maintenance practices

Routine visit by qualified personnel to perform tests

• **Effect:** Capable of identifying blind spot faults

• **Pros:**

- O&M can find undetected faults and degraded insulation
- Annual operation and maintenance inspections are useful for many reasons beyond the blind spot.
- **Cons:**
- Requires routine visit by technicians to perform tests.
- Faults that occur between inspections may still go undetected.
- Not a blind spot cure

• **Cost:** Moderate, but recurring



Method 7: Use of arc-fault detection

Series arc fault current interrupters (AFCIs) installed in contactor combiner boxes or at inverter feeder input circuits

- **Effect:** Can isolate circuits when arc is detected
- **Pros:**
 - Isolating strings when arc is detected may lessen any fault severity
 - May isolate 2nd dangerous fault that follows a blind spot fault (becomes series arc).
 - Detects other fire-causing faults
- **Cons:**
 - AFCI may not be able to detect blind spot faults
 - Series AFCIs are not evaluated for response to arcing faults to ground.
 - Limited commercial availability of proven equipment
- **Cost:** High (expected)

