

THE GROUND-FAULT PROTECTION
BLIND SPOT:
A SAFETY CONCERN FOR LARGER
PHOTOVOLTAIC SYSTEMS
IN THE UNITED STATES

A Solar ABCs White Paper

January 2012

Prepared for:
Solar America Board for
Codes and Standards

Bill Brooks
www.brooksolar.com

Solar America Board for Codes and Standards

www.solarabcs.org



Solar America Board for Codes and Standards White Paper

THE GROUND-FAULT PROTECTION BLIND SPOT: A SAFETY CONCERN FOR LARGER PHOTOVOLTAIC SYSTEMS IN THE UNITED STATES

Prepared for:
Solar America Board for Codes and Standards

Bill Brooks
www.brooksolar.com

January 2012

DISCLAIMER

This report was prepared as an account of work sponsored by an agency of the United States government. Neither the United States government nor any agency thereof, nor any of their employees, makes any warranty, express or implied, or assumes any legal liability or responsibility for the accuracy, completeness, or usefulness of any information, apparatus, product, or process disclosed, or represents that its use would not infringe privately owned rights. Reference herein to any specific commercial product, process, or service by trade name, trademark, manufacturer, or otherwise does not necessarily constitute or imply its endorsement, recommendation, or favoring by the United States government or any agency thereof. The views and opinions of authors expressed herein do not necessarily state or reflect those of the United States government or any agency thereof.

Download a copy of the report:

www.solarabcs.org/blindspot

EXECUTIVE SUMMARY

This document addresses an important safety issue in the design of many U.S. photovoltaic (PV) systems. This safety issue—undetected faults in grounded PV array conductors—came to light during investigations into two well-publicized PV system fires. The first occurred on April 5, 2008, in Bakersfield, California, and the second occurred on April 16, 2011, in Mount Holly, North Carolina.

The investigations into these fires expose a “blind spot” in ground-fault protection in larger PV systems and provide an opportunity to explore the safety implications of inadequate ground-fault protection in a public forum. As investigators develop an understanding of the root causes of the Bakersfield and Mount Holly fires, they will also develop a better understanding of the complex nature of faults and fault currents in PV arrays, which will benefit all stakeholders.

This paper provides a basic explanation of the cause of these fires, followed by an outline of a limited research plan designed to develop solutions. It also includes preliminary fire mitigation strategies and equipment retrofit recommendations to reduce fire danger in new and retrofit applications based on results of the fire investigations to date.

The preliminary mitigation strategies and equipment retrofit recommendations listed in this white paper include:

- proper installation techniques with close attention to wire management,
- annual preventative maintenance to identify and resolve progressive system damage,
- introduction to the use of data acquisition to monitor the operation of all PV systems at a level sufficient to determine if unscheduled maintenance is required, and
- additional ground-fault and PV array isolation sensing devices that can be incorporated into the data system to alert operators to potential problems so that maintenance personnel can be dispatched well in advance of damage that could lead to a fire.

The Solar America Board for Codes and Standards (Solar ABCs) is leading a broad industry- and stakeholder-based working group to research this problem and develop effective mitigation strategies. Until the working group research is completed, it is not known which inverters and which GFDI schemes are most susceptible to the blind spot phenomenon, but larger inverters with the blind spot represent a potential fire hazard that must be addressed. Early results from large PV systems retrofitted with protective devices indicate that these devices may eliminate the blind spot without requiring redesign of the system.

The types of protective devices that have currently been retrofitted to existing inverters for evaluation include:

- differential current sensors (also known as residual current detectors or RCDs) installed on feeders entering the array combiners on each system, and
- insulation resistance monitors that measure the resistance to ground on a PV array while it is not operating.

In addition, other protective equipment may help mitigate fire danger in new systems, including:

- contactor combiners, which constitute an additional safety step beyond the differential current sensors and insulation monitors included in new inverters;
- arc fault detectors, which are required by the 2011 National Electrical Code; and
- module-level controls, which can shut the power off from each module.

Based on the limited investigations to date, it is recommended that PV systems with damaged conductors be identified and repaired as soon as practical. Once the Solar ABCs research project is complete, a final report will be published to inform all potentially affected PV system owners of all findings and recommendations necessary for them to make informed decisions about whether or not to implement retrofit or other proposed modifications.

AUTHOR BIOGRAPHY

Bill Brooks

Bill Brooks has worked with utility-interconnected photovoltaic (PV) systems since the late 1980s. He is a consultant to the PV industry on a variety of performance, troubleshooting, and training topics. During the past 11 years, his training workshops have helped thousands of local inspectors, electricians, and installers understand and properly install PV systems.

His field troubleshooting skills have been valuable in determining where problems occur so that training can focus on the issues of greatest need. Mr. Brooks has written several important technical manuals for the industry that are now widely used in California and beyond. His experience includes work on technical committees for the National Electrical Code, Article 690, and IEEE utility interconnection standards for PV systems. In 2008, the Solar Energy Industries Association appointed him to Code Making Panel 4 of the National Electrical Code.

Mr. Brooks holds bachelor and master of science degrees in mechanical engineering from North Carolina State University and is a registered professional engineer in both North Carolina and California.

Brooks Engineering Website: www.brooksolar.com

SOLAR AMERICA BOARD FOR CODES AND STANDARDS

The Solar America Board for Codes and Standards (Solar ABCs) is a collaborative effort among experts to formally gather and prioritize input from the broad spectrum of solar photovoltaic stakeholders including policy makers, manufacturers, installers, and consumers resulting in coordinated recommendations to codes and standards making bodies for existing and new solar technologies. The U.S. Department of Energy funds Solar ABCs as part of its commitment to facilitate widespread adoption of safe, reliable, and cost-effective solar technologies.

Solar America Board for Codes and Standards website:
www.solarabcs.org

TABLE OF CONTENTS

1	Introduction.....	1
2	The Problem—Ineffective Ground-Fault Protection	2
2.1	The Bakersfield and Mount Holly Fires	2
2.2	A Common Thread.....	2
2.3	The Sequence of Events Leading to the Fires.....	3
3	Codes and Standards Requirements	7
3.1	National Electrical Code	7
3.2	Ground-Fault Protection Device Test Standard	7
3.3	The Blind Spot.....	7
4	The Root Cause	9
5	Solar ABCs Ground-Fault Blind Spot Research Project	10
6	Possible Mitigation Strategies to Prevent Fires in Large PV Systems.....	11
6.1	Installation Inspections	11
6.2	Annual Preventative Maintenance	12
6.3	PV System Monitoring.....	12
6.4	Possible Retrofits for Existing PV Systems	14
6.5	Equipment to Consider for New PV Systems	15
6.6	Implementation of Mitigation Strategies.....	16

1. INTRODUCTION

This document addresses an important safety issue in the design of many U.S. photovoltaic (PV) systems. This safety issue—undetected faults in grounded PV array conductors—came to light during investigations into two well-publicized PV system fires. The first occurred on April 5, 2008, in Bakersfield, California, and the second occurred on April 16, 2011, in Mount Holly, North Carolina.

There have been other similar fires, but they are not public knowledge and investigation results are not available for open discussion. The fires at Bakersfield and Mount Holly, therefore, provide an opportunity to explore the safety implications of suspected inadequate ground-fault protection in a public forum.

Solar America Board for Codes and Standards (Solar ABCs) has initiated a short-term research project with broad participation from PV industry, owners, and the enforcement community to better understand the blind spot problem and develop recommendations to address any safety concerns. Ultimately, however, the individual PV system owner will have to evaluate the risk and decide which recommended corrective actions to implement.

The intent of this white paper is not to blame PV component and system installers, designers, or manufacturers. As investigators develop an understanding of the root causes of these fires, they also develop a better understanding of the complex nature of faults and fault currents in PV arrays, a valuable benefit to all stakeholders.

This paper provides a basic explanation of the current understanding of the cause of these fires, followed by an outline of a limited research plan designed to propose solutions. Based on results of this research, Solar ABCs will recommend strategies for mitigating future fires in existing and new installations. Effective ground-fault detection is a high priority for ensuring the safety of PV systems in the United States.

2. THE PROBLEM—INEFFECTIVE GROUND-FAULT PROTECTION

2.1 The Bakersfield and Mount Holly Fires

Pete Jackson, an electrical specialist with the city of Bakersfield, documented the Bakersfield fire (Jackson, 2009) shortly after the event. The Jackson report provides basic insight into the cause of the fire, but lacks emphasis on key factors that contributed to the fire. The author of this white paper wrote a follow-on article for *SolarPro* magazine (Brooks, 2011) that expands on Jackson's report and emphasizes the larger safety concerns that the Bakersfield Fire exposed. Based on an understanding of the source of the Bakersfield fire, the article predicted that similar fires would occur in the future.

The April 16, 2011, fire in Mount Holly, North Carolina, was such a recurrence. This fire was documented in a report for Duke Energy by this author, which has seen limited but open distribution within the utility community. Many of the key details of that report are presented in this white paper.

2.2 A Common Thread

Both reference fires show evidence of significant arcing at one location in the PV array, although the fire ignited in a completely different section of the array. That is, in both fires there was significant damage in a seemingly unrelated portion of the array away from the initial sources of ignition. Jackson connects the coincidence of these faults in his report, but he questions the likelihood of a repeat event. The *SolarPro* article showed that the problem was ultimately in the blind spot of ground-fault protection equipment and therefore an apparent general concern to the PV industry in the United States.

As in the Bakersfield Fire, the Mount Holly fire caused significant damage in two different locations at the same time. At Mount Holly, the faults existed inside two different combiner boxes at the same time. The likelihood of these two faults initiating simultaneously in different locations is extremely small. Thus, it is likely that one fault existed for some period of time prior to the initiation of the second one. This is the fundamental insight that led to an understanding of the root cause of the fires.

In summary, it appears that at some time before the ignition of the fires, one fault occurred that was allowed to continue undetected, apparently due to an ineffective ground-fault detection scheme.

The National Electrical Code (NEC) and Underwriters Laboratories (UL) 1741 require that a ground-fault detector and interrupter (GFDI) be part of every PV system. Traditional safety requirements are based upon a single fault scenario. However, a problem may arise with a ground fault occurring in the grounded PV array conductor (the array positive or negative conductor that is bonded to earth ground, typically in the inverter). If this fault does not trip the GFDI, a current path may be created which inhibits an inverter from interrupting future ground faults when they occur. Within this white paper, ground faults on the grounded conductor of insufficient magnitude to be detected by existing ground-fault equipment are said to fall within a detection “blind spot.” The blind spot is a potential condition that can occur in any conductor of the grounded pole of an array.

Recent system reviews by the Solar ABCs team and others have found that faults on grounded conductors in a PV array can be extremely difficult to detect with methods typically used in currently available ground-fault protection equipment. This is because the conductor is already grounded, so additional grounds on the conductor have little voltage differential to drive the current necessary to blow the protective ground-fault fuse. In this undetected condition, ground faults on the grounded conductor may exist indefinitely in a PV array, establishing a new “normal” condition that renders the ground-fault protection device unable to interrupt a second ground-fault current. In this condition, the clearing of the ground-fault fuse caused by an ungrounded conductor fault may drive the fire event by applying 500 volts to the first initially grounded conductor fault location.

2.3 The Sequence of Events Leading to the Fires

Based on the author’s investigation, a similar sequence of events preceded the fires in Bakersfield and Mount Holly. In both cases, the evidence suggests that an undetected fault existed in the grounded conductor of the array. The line diagram in Figure 1 shows a ground-faulted string conductor similar to the likely first fault in the Bakersfield fire. The line diagram in Figure 2 shows a ground-faulted subarray conductor similar to the likely first fault in the Mount Holly fire. How long these assumed faults existed is unknown.

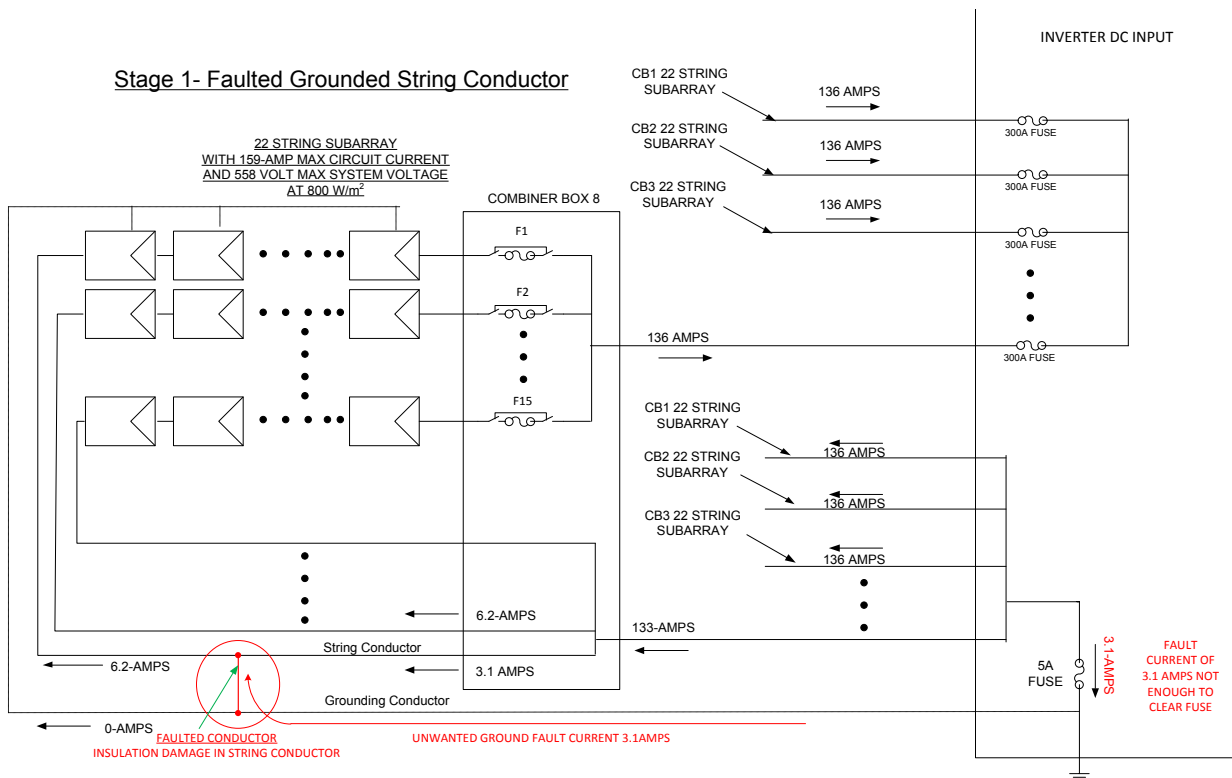

Figure 1: Ground-Faulted String Conductor, the Assumed First Fault—Bakersfield Fire

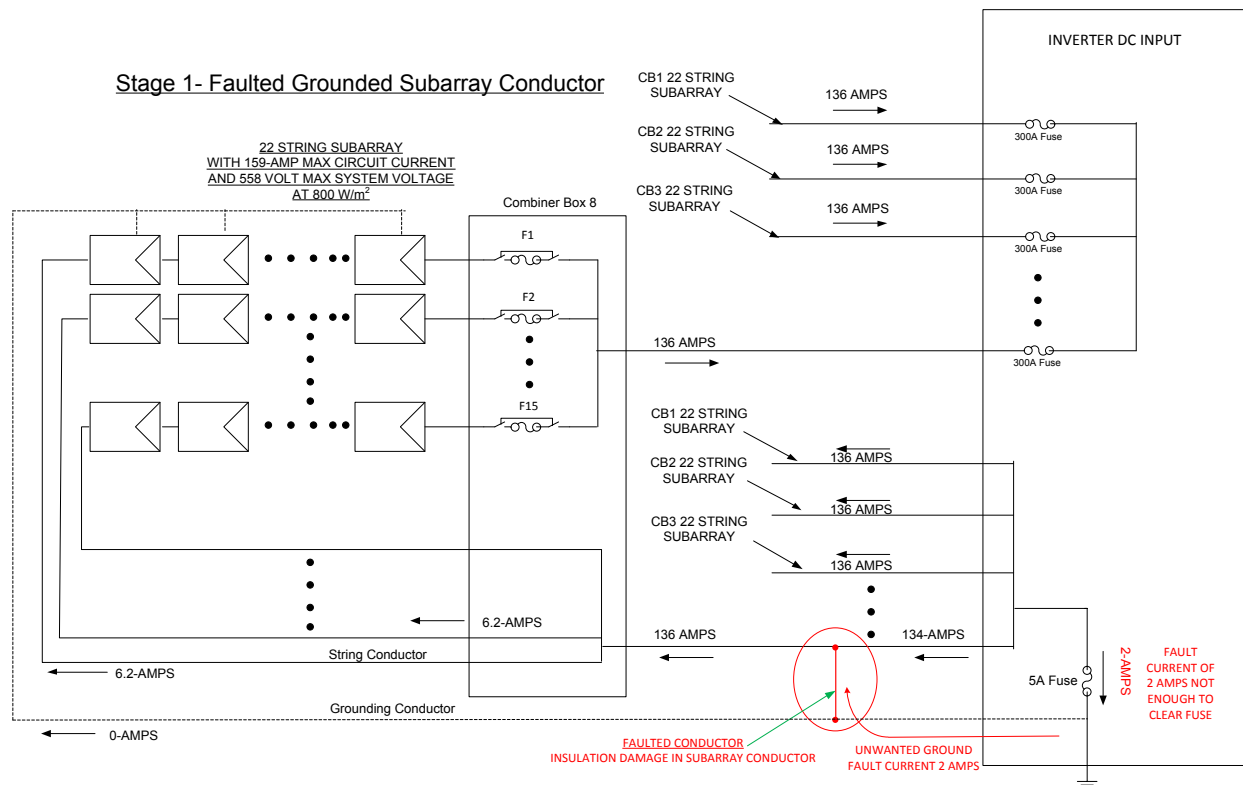

Figure 2: Ground-Faulted Subarray Conductor, the Assumed First Fault—Mount Holly Fire

The evidence suggests that sometime after the initiation of an undetected fault in the grounded conductor, a second fault occurred in the ungrounded conductor. Ordinarily, when a fault is detected on the ungrounded conductor, the ground-fault detection circuit opens the ground-fault fuse, thus opening the faulted circuit and interrupting all current flow.

As the figures illustrate, when there is an existing fault in the grounded conductor, blowing the ground-fault fuse can no longer interrupt all fault current. Because a return path has already been established in the faulted grounded conductor, the array becomes short circuited between the faulted grounded conductor and the second ungrounded conductor fault. The ground-fault protector in the inverter is not in this circuit and is unable to stop the flow of current.

Figure 3 shows the second fault in a fire similar to the Bakersfield event. In this scenario, the short circuit current is forced through the small 10 American wire gauge (AWG) grounded string conductor, causing a conductor insulation fire. Figure 4 shows the second fault in a fire similar to the Mount Holly event, in which the array short circuit current is forced through the poor inadvertent grounding connection, causing an arcing fire.

A 500-kilowatt (kW) PV array can have more than 1,300 amps of available short circuit current, which can cause enormous damage during this short circuit condition. If the two connection points were intentionally made with terminations able to handle the current, there would be little if any hazard. Unfortunately, these connections are made with only incidental contact that can evolve dramatically into intense arcs with operating temperatures of more than 2,000°C. These arcs can jump gaps between metal parts up to six inches apart.

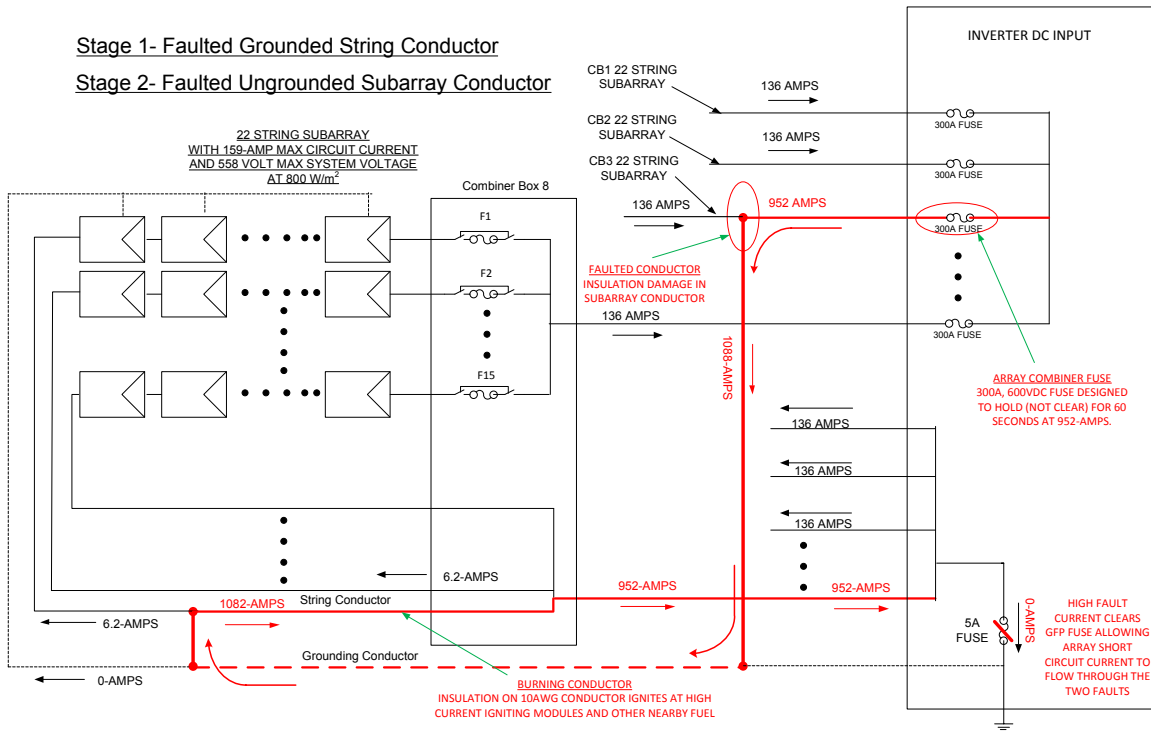

Figure 3: Second Ground-Faulted Conductor, Representative of the Bakersfield Fire

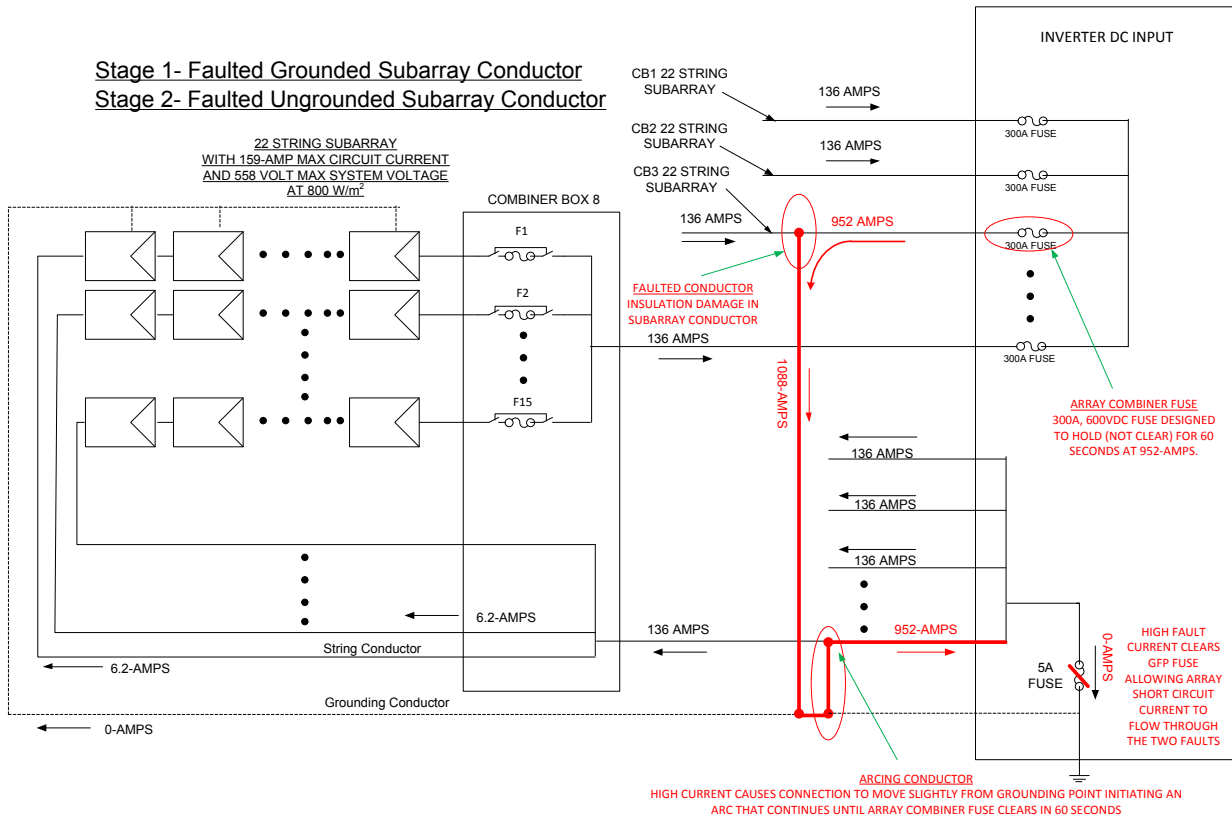

Figure 4: Second Ground-Faulted Conductor, Representative of the Mount Holly Fire

3. CODES AND STANDARDS REQUIREMENTS

3.1 National Electrical Code

The NEC, in article 690.5 (A), requires the following:

(A) Ground-Fault Detection and Interruption. The ground-fault protection device or system shall be capable of detecting a ground-fault current, interrupting the flow of fault current, and providing an indication of the fault.

The requirement in the NEC and UL 1741 standard that covers PV inverters addresses only ground-fault current in grounded PV systems. The NEC requirements do not address fault locations or fault current trip limits. Experience in the United States has found that although fault current is undesirable, all U.S. PV arrays have small current flows to ground, generally referred to as leakage current. These current flows increase in larger PV arrays and with certain PV module technologies and designs.

3.2 Ground-Fault Protection Device Test Standard

The present version of UL 1741 requires inverters to detect ground faults based on the magnitude of the fault current measured by the GFDI device. The trip limits set in the standard are based on the size of the system, and are derived by extrapolating the maximum allowable leakage current from a single PV module to the leakage from a large array field. The trip current limits are set conservatively to prevent nuisance tripping, particularly for modules that only marginally meet the leakage requirements. The allowable trip limits in UL 1741 range from 1 amp for inverters rated up to 25 kW to 5 amps for inverters greater than 250 kW.

3.3 The Blind Spot

If a ground fault occurs with current less than the trip threshold established by the UL 1741 standard, it cannot be detected or “seen” by the GFDI device. Hence, in this context, the device is said to have a blind spot (more formally known as a “lower limit of detection”). It is axiomatic that bigger PV systems, which have higher trip thresholds than smaller systems, must also have a larger blind spot than smaller systems.

This may explain why our first observations of this problem occurred in larger PV systems. With research, we may find that scenarios that lead to fires can also develop in smaller PV systems with smaller detection thresholds, possibly coupled with reduced short circuit current designs. A key area of focus for future Solar ABCs research will be understanding minimum system sizes that have a blind spot and identifying the appropriate fault current detection settings that enable the system to operate safely.

4. THE ROOT CAUSE

A large fire often consumes the evidence of its origins. However, what evidence remained from the two fires under discussion here suggests similar root causes.

The evidence suggests that the ignition of the Bakersfield fire resulted from two faults occurring in two significantly different wire sizes in the PV array. The first fault was in a small grounded conductor. Failure to detect this first fault created the potential for the faulted grounded conductor to become part of a circuit for which it was not designed.

Physical evidence from the Bakersfield fire suggests that about 1,000 amps flowed through the faulted grounded conductor, a small unprotected 10 AWG wire. The wire insulation burned and ignited other fuel in the immediate vicinity. Because NEC installation requirements do not allow overcurrent protection devices in the grounded conductors of grounded PV arrays [NEC Article 690.13], full array current flowed unimpeded through the ground fault in the string-level wiring of the Bakersfield system.

The same scenario is suggested in the Mount Holly fire, but here the evidence indicates that both faults occurred in large combiner box feeder conductors. This was unexpected, because conventional wisdom assumes that a fault in a grounded large conductor would blow the ground-fault fuse and shut down the inverter. However, full

review of the Mount Holly fire suggests that even large grounded feeder conductors can be faulted and remain in the blind spot of the ground-fault protection device. Two months before the Mount Holly fire, maintenance inspection personnel photographed conductor insulation damage in two sections of the array that were later severely damaged in the fire. Although the inspectors were concerned that this damage would cause the ground-fault protection system in the inverter to shut the system down, they did not fully understand the threat of fire because so few fires have been reported.

5. SOLAR ABCs GROUND-FAULT BLIND SPOT RESEARCH PROJECT

Solar ABCs has initiated a short-term research project to better understand the blind spot problem and develop recommendations to guide the PV industry as it addresses any safety concerns. Ultimately, the PV system owner must evaluate the risk and implement corrective actions. This evaluation requires a solid basis of data in order to make informed decisions.

The Solar ABCs research project has the following objectives:

- Determine the conditions under which existing ground-fault protection is inadequate. For example, confirm the identification of “systems at risk” with field tests by metering systems with no faults, introducing a fault, and observing whether the inverter detects the fault. Factors to examine include:
 - array size, age, topology, and possibly climate (what is the minimum system size that will develop the blind spot problem, for example.);
 - different PV technologies, including crystalline and thin-film and their respective leakage characteristics; and
 - protection schemes used by inverters that are either effective or ineffective at detecting the introduced fault.
- Develop a mitigation proposal that can be implemented through changes to the *NEC* and *UL* standards.
 - The mitigation proposal currently under consideration is a combination of a morning check and detection of fault current by measuring differential current. The research project will determine values for insulation resistance and differential current.

The Solar ABCs will publish a final report detailing the research results and possible new system design guidelines to improve the safety of future PV systems.

6. POSSIBLE MITIGATION STRATEGIES TO PREVENT FIRES IN LARGE PV SYSTEMS

Owners of large PV systems should consider the following fire mitigation strategies, which, although not comprehensive, are based on an analysis of the probable causes of recent fires. As noted earlier, refinement of these and additional mitigation means may be identified when the Solar ABCs team completes its testing and analysis.

Field experience suggests several steps in the design, installation, and maintenance of a PV system that must be followed to prevent PV system fires. These steps include:

- using proper installation techniques with close attention to wire management, such as taking care to avoid abrading insulation and using correctly-sized wire;
- performing annual preventative maintenance to identify and resolve progressive system damage due to thermal cycling and mechanical vibration;
- using detailed data acquisition to monitor PV system operations and determine if unscheduled maintenance is required; and

- installing additional ground-fault and PV array isolation sensing devices that can be incorporated into the data system to alert operators about potential problems so that maintenance personnel can be dispatched in advance of a failure that could lead to a fire.

6.1 Installation Inspections

The first step in preventing or mitigating ground faults must be taken prior to energizing the array for the first time. Conduct a detailed review of all installation-related issues and develop a punch list to address concerns, including wire management, grounding, and equipment installation for the entire system. Once the punch list has been resolved, the commissioning procedure should include:

- insulation resistance tests on all field-installed conductors, including modules and module wiring;
- open-circuit voltage and polarity tests on all string and feeder circuits;
- operational current readings on all series strings and feeders; and
- thermography of all inverters, disconnects, and combiner boxes at 50 % load or higher as well as thermography of the array to scan for hot spots not caused by shading or other normal temporary conditions.

6.2 Annual Preventative Maintenance

Next, develop a maintenance schedule that establishes consistent inspection, documentation, and maintenance procedures to identify and correct problems before they result in a fire. The fact that a maintenance inspection prior to the Mount Holly fire identified conductor damage that was later recognized as a potential cause of the subsequent fire reveals the value of this type of inspection. This case also highlights the need to adequately train maintenance personnel so that they recognize the visual and testing indicators that a fire is possible.

- Maintenance procedures should include:
- visual inspection of all equipment and field connections in equipment for signs of damage or degradation;
- visual inspection of all accessible electrical junction boxes and raceways to see if conductors are damaged and in need of repair or replacement;
- visual inspection of string conductors to identify any physical damage that is in need of repair and additional protection to prevent progressive damage;
- operating voltage and current tests at defined conditions of irradiance and module temperature to compare output of strings;
- insulation resistance testing of modules, string wiring, and photovoltaic output circuits in the array (sometimes referred to as a “megger” test); and
- thermography of all inverters, disconnects, and combiner boxes at 50 % load or higher, as well as thermography of the array to scan for hot spots not caused by shading or other normal temporary conditions.

6.3 PV System Monitoring

Another step that owners of large PV systems can take to mitigate the risk of undetected ground faults is to install and use automated performance monitoring instrumentation that recognizes ground faults and other equipment failures as soon as they occur. Performance monitoring and regular data review can be key elements in the safe operation of any power plant. Careful attention to system and subsystem data trends enables early recognition of component failures, and helps to establish effective maintenance schedules that ensure reliable long-term operation. The following is a description of a generic monitoring program based on best practices identified by the author. It is offered as a model and not a solution to all monitoring requirements.

Monitoring systems should include one-second data averaged, recorded, and accurately time-stamped at a minimum of every 15 minutes, and preferably every five minutes. With some averaged values, a minimum and maximum value for each time period can provide insight into the range of values that the average represents.

Averages and minimum/maximum values should be recorded for:

- plane of array irradiance,
- ambient temperature and wind speed,
- alternating current (AC) voltage on each inverter,
- AC power output on each inverter, and
- ground fault current on each inverter.

Items requiring averaged data include:

- direct current (DC) voltage on each inverter,
- DC current on each inverter, and
- morning array insulation resistance (recorded once a day).

Optional items include:

- string currents,
- ground fault current on each PV power source circuit,
- array temperature (back of representative module),
- global horizontal irradiance, and
- wind direction.

One important use of this data is to establish the daily performance index (PI) based on actual versus expected performance. PI is a daily value that is calculated based on irradiance, temperature, wind speed, and system configuration.

A response schedule should be established when the data shows:

- an inverter off-line,
- performance of less than 90% of expected PI,
- differential current above the prescribed maximum threshold, or
- ground resistance less than the prescribed minimum threshold.

6.4 Possible Retrofits for Existing PV Systems

Finally, the Solar ABCs research will help identify which inverter designs have GFDI schemes susceptible to the blind spot phenomenon and suggest retrofits that may be able to eliminate the blind spot without requiring redesign of the system. Because of the larger power involved, it is expected that larger inverters with the blind spot represent a potential fire hazard that should be addressed. The following protective devices and system retrofit modifications may provide additional protection from grounded conductor ground faults and can be tailored for the leakage current of the specific PV arrays.

6.4.1.1 Differential Current Measurement

The simplest pieces of equipment to add to existing systems are differential current sensors (also known as residual current detectors or RCDs) installed on feeders entering the array combiners on each system. Array conductors can be bundled and run through the current transducers of the RCD, but to the extent possible, it is better to use individual sensors installed on the individual subarray conductors to achieve the highest resolution of differential current. Some commercial residual current monitors can monitor up to 12 current sensors. Employing multiple sensors on a large PV array increases the sensitivity of ground-fault current measurements by making measurements on smaller array segments. Breaking the array into smaller segments allows use of lower trip current levels and significantly reduces the blind spot in large arrays associated with the use of large ground-fault fuse sizes.

6.4.1.2 Insulation Resistance Monitor

A second important piece of equipment needed to eliminate the blind spot is an existing product used to measure the resistance to ground on a PV array. This measurement should be taken every morning prior to the operation of a grounded PV inverter, and should be taken while the array is in open circuit condition. Before determining array resistance to ground, the operator may need to open a contactor to isolate the “grounded” conductor from ground during this measurement. Some inverters have a grounding contactor option. Without such an option on a DC grounded PV array, a separate device that operates independently of the inverter would be necessary.

Once the test has been completed, the array insulation monitor device either will report that the system is free to start normally for the day or it will signal that the ground resistance is below the minimum allowable value and prevent the inverter from starting. In the latter case, the inverter will remain offline, providing indication of a fault and reducing the possibility of a fire.

6.5 Equipment to Consider for New PV Systems

In addition to the equipment recommended for retrofitting existing systems, new system designers should consider the following equipment to improve safety.

6.5 Ungrounded Inverters

The basis for the problem outlined in this document is the fact that the array conductors are solidly grounded, thus making it difficult to detect insulation damage in the grounded conductors. Systems in much of the world do not have conductors solidly grounded on the DC side of the inverter. These ungrounded systems employ more sensitive methods to detect ground faults. Recently, the inverter test standard, UL1741, has been updated to include requirements for transformerless and other ungrounded inverters. Until that standard was updated, few inverter manufacturers were willing to bring ungrounded inverters into the United States. With that technical issue resolved, the door is open for many ungrounded inverter designs to be certified and installed in U.S. systems. Ungrounded inverters (and systems) are not susceptible to the blind spot problem.

6.5.1.1 Contactor Combiners

Differential current sensors and insulation monitors are included in new inverters, but using contactor combiners can provide additional safety. These combiners can de-energize the feeder circuits from the combiner boxes to the array combiners when the AC power is disconnected. As noted earlier, the control circuit for the contactor combiners can be wired through a relay at the inverter controlled by the differential current sensors and the insulation monitor.

Products are also available that provide string-level differential current measurements, and individually isolate a faulted string from the rest of the array. Combined with monitoring, this can provide immediate notification that a fault exists.

6.5.1.2 Arc Fault Detectors

Although the three measures discussed above will go far to eliminate the causes of most fires, they cannot address series arc faults. Series arc faults occur when an electrical connection comes apart under load. These arc faults are particularly problematic because the arc condition is stable and remains until the conductor erodes to the point that it burns away. Unfortunately, if combustible material is present, as it was in both the Bakersfield and Mount Holly fires, the fire will continue burning after the arc extinguishes.

The probability of an arcing fault, though less likely than the faults that caused the Bakersfield and Mount Holly fires, remains high enough to justify installing arc fault detectors. The 2011 National Electrical Code requires arc fault detectors, which are expected to be available in 2012. These units may include contactor combiners or string-level control and feature ground-fault detection functions.

6.5.1.4 Module-Level Controls

Below the string level, the only way to reduce the voltage within the PV array to levels too small to initiate arcing is for electronics to be installed at the PV module. These electronics, often referred to as module-level control, or “smart modules,” can be designed to shut off the power from each individual PV module, thus removing the source of fault current and the voltage that could shock a technician or firefighter. Recently introduced products claim to have these features, but testing standards are not yet available to certify that a product can perform this safety function reliably. As adequate certification test procedures are developed, these products should be considered for new installations and even for retrofitting existing systems.

6.6 Implementation of Mitigation Strategies

The Solar ABCs team is evaluating the mitigation approaches described in this report to refine its recommendations for PV system owners. Implementing these strategies will take time, and all the strategies may not be necessary for every PV system. Some of the equipment is not yet on the market, and implementation will require a phased approach.

PV systems with damaged conductors must be identified and repaired as soon as practical. Once the conductor damage is addressed, the differential current monitors can be installed and incorporated into the inverter controls. After these initial steps, owners can add the other measures over time to further enhance safety.

REFERENCES

Brooks, B. (Bill). (2011). "The Bakersfield fire." *SolarPro* magazine, February/March 2011, page 62. <http://solarprofessional.com/home/>. [Access requires free subscription.]

Jackson, P. (Pete). (2009). Bakersfield fire report. Investigator's report, April 29, 2009. <http://nfpa.typepad.com/files/target-fire-report-09apr29.pdf>.